



**BROTHERS**  
PHARMAMACH (INDIA) PVT. LTD.

## STICKER (Self-Adhesive) LABELLING

### LABELSTIK-120H Automatic Horizontal Sticker Labelling Machine

The Automatic Horizontal Sticker Labelling Machine Model LABELSTIK-120H, is one of the most user friendly. The Machine incorporates latest sophisticated Micro Processor Control Label Dispensing system with user friendly Sensing system for Label and Product. The machine is suitable for Labelling on unstable small diameter round objects. It is capable of Labelling up to 120 units per minute depending on product diameter and label size. Machine suitable for Round Ampoules, Vials, Pre-Fill Syringes, Inhalers and other Small Sizes of round objects. Machine with Optional Product feeding hopper for regular shaped round objects for continues feeding.

The Sticker Labelling Machine LABELSTIK-120H has its own unique single point synchronised speed control system. The Inbuilt Automated Label Length detection systems eliminates any need for manually feeding and storing of Label Length data in memory and retrieving the same every time for change of Label Size & re-starting the machine. The System thus saves valuable time, avoiding machine-down time, and helps achieve higher production. Machine can be supplied with Optional Toughened (Tampered) Glass or Acrylic Safety Cabinet. Machines having required all basic features as a standard fitment to match the current market needs and also saves cost and time.



### **BUILT-IN UNIQUE FEATURES :**

- No Label Data Input/retrievals require for any Label Size
- No Change Parts for Label size, Star Wheel require for Feeding Hopper
- Single Pot On-line Speed Variation control
- Synchronized speed of Label Dispensing, Conveyor and Pressing Device
- Virtually Maintenance free machine
- Easy to change label application height
- User Friendly Label Placing Adjustments
- Self Protected against Voltage Fluctuations
- Suitable for On-Line InkJet and Contact Coding System
- Suitable for Partial, Full Wrap Around and Overlap Labelling
- Built In A.C. Variable Frequency Drive System.
- Fully Stainless Steel finish Machine

\* Refer Plug & Play Sticker Labelling UNIQUE FEATURES page for more details

Note: Machine not available with all Optional features, contact us for more detail.

## TECHNICAL SPECIFICATIONS

Label Height : 8 mm to 70 mm Standard\*  
 Label Length : 12 mm Minimum  
 Label Roll Dia. : 400 mm  
 Core Dia. : 75/76 mm  
 Gap Between two Labels : appx. 3 mm  
 Product Diameter : Up to 25 mm\* We need to check actual product samples  
 Electrical : 220 VAC Single Phase Power Supply (50/60 Hz)  
 Power : 1.5 Amp.  
 Capacity : 0.75 Kw  
 Speed : Up to 120 Labels per minute depending on Product and Label Size  
 Conveyor height : 830-875 mm\*  
 Overall dimension : 1750 mm(L) X 870 mm(W) X 1500 mm (H)  
 Machine Direction of Movement : Left to Right from operator side

\* Specification can be changed as per customers requirements

## OPTIONAL FEATURES :

- Label Roll Empty - Machine Stop System with Alarm
- Missing Label in Roll - Machine Stop System with Alarm
- Special Label Sensor for sensing Transparent Film Labels which does not have any sensing mark on it.
- Option of Contact Coder, Hot Foil Coder, HP Cartridge Coder and Inkjet Coder with various speed range available.
- Toughened Glass or Acrylic Safety Cabinet for Machine
- Tower Light showing the machine status / operation
- Colour or Mono Touch Screen with PLC for machine operation and showing various error messages and information on display
- Special Sensing system for checking missing label on product
- Low Compressed Air - Machine Stop with Alarm system for pneumatically operated coding system
- Vision System for checking Barcode, presence or absence of Coding or pharma code on labels
- Vision System with OCV / OCR system for checking coding on labels
- Online pneumatically operated product rejection system
- Longer infed Conveyor for Manual Product Feeding on conveyor

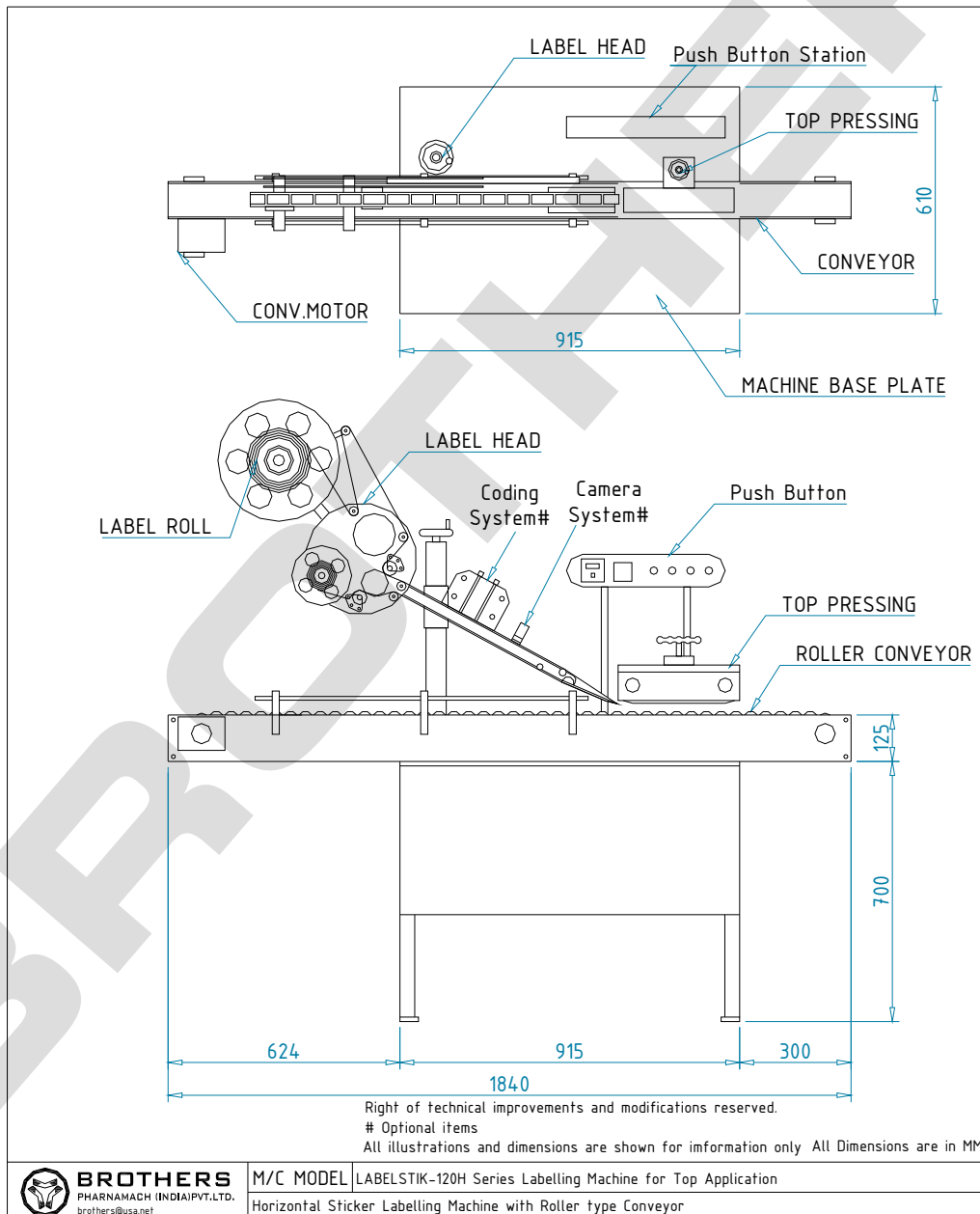

## BROTHERS PHARMAMACH (INDIA) PVT. LTD.

Plot No.2, Phase II, GIDC, Vatva, Ahmedabad 382445. INDIA

Phone : +91 79 40213213, 25831346, 29708139

Fax: +91 79 40213220, 25835885

+91 9825037971, 9825006052

Email : sales@brothers.in mevada@usa.net

Website : www.brothers.in

**BROTHERS**